

Plan View

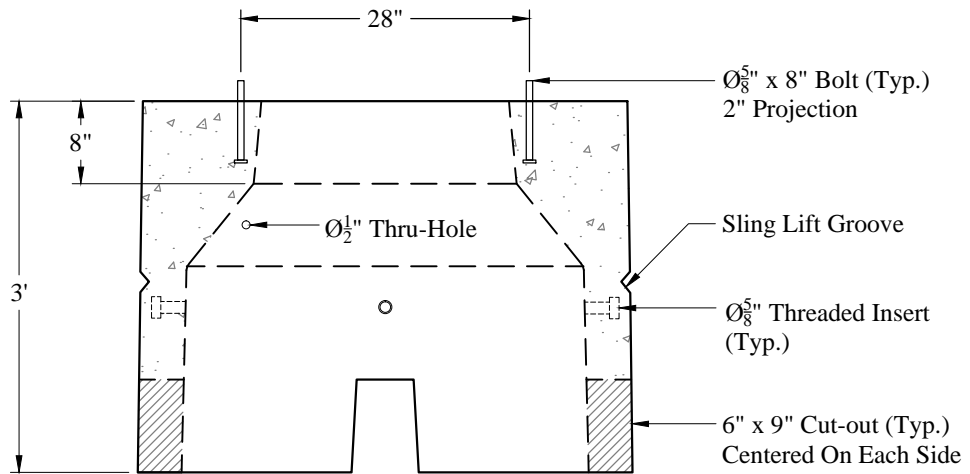

Front View

Est. Weight: 3,270 Lbs

**General Notes:**

1. Reinforcement Steel Conforms to:  
ASTM A185 Welded Wire Fabric
2. Concrete:  $f_c = 5,000$  psi @ 28 Days Minimum

**Phoenix  
Precast  
Products**

**Central Maine Power  
Single Phase Transformer  
Foundation (25-167 KVA)**

**P/N: CMP-1PHTF**